



IM-4D Icemaker Accessory Kit

Safety Information 2

Operating Instructions 3

Before You Call For Service 5, 6

Normal Sounds You May Hear 3

Preparing for Vacation 3

When You Should Set the
Icemaker Power Switch to OFF 3

Installation Instructions

Icemaker Installation 7-13

Water Line Installation 18-21

Water Valve Assembly Installation .. 14-17

Consumer Support

Consumer Support Back Cover

Warranty 22

*Owner's Manual and
Installation Instructions*

Trousse

Machine à glaçons

*Manuel d'utilisation
et d'installation*

La section française commence à la page 23

Equipo de Accesorios

Máquina de Hielos

*Manual del propietario
e instalación*

La sección en español empieza en la página 45

IMPORTANT SAFETY INFORMATION. READ ALL INSTRUCTIONS BEFORE USING.

 This is the safety alert symbol. This symbol alerts you to potential hazards that can kill or hurt you and others. All safety messages will follow the safety alert symbol and the word "DANGER", "WARNING", or "CAUTION". These words are defined as:

 **DANGER**

Indicates a hazardous situation which, if not avoided, **will** result in death or serious injury.

 **WARNING**

Indicates a hazardous situation which, if not avoided, **could** result in death or serious injury.

 **CAUTION**

Indicates a hazardous situation which, if not avoided, **could** result in minor or moderate injury.

State of California Proposition 65 Warnings:

 **WARNING**

This product contains one or more chemicals known to the State of California to cause cancer and birth defects or other reproductive harm.

SAFETY PRECAUTIONS

 **CAUTION**

Do not place fingers or hands in the automatic icemaking mechanism while the refrigerator is plugged in. This will help protect you from possible injury.

It will also prevent interference with moving parts of the ejector mechanism and the heating element that releases the cubes, located on the bottom of the icemaker.



***READ AND FOLLOW THIS SAFETY INFORMATION CAREFULLY.
READ AND SAVE THESE INSTRUCTIONS***

A newly-installed refrigerator may take 12 to 24 hours to begin making ice.

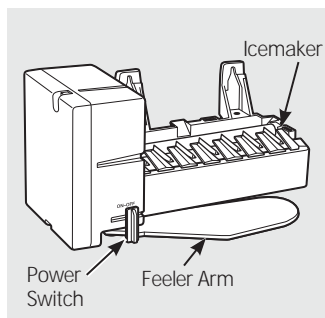

(Appearance may vary)

Automatic Icemaker

The icemaker will produce seven cubes per cycle—approximately 100–130 cubes in a 24-hour period, depending on freezer compartment temperature, room temperature, number of door openings and other use conditions.

If the refrigerator is operated before the water connection is made to the icemaker, set the power switch to **OFF**.

When the refrigerator has been connected to the water supply, set the power switch to **ON**.

The icemaker will fill with water when it cools to freezing. A newly-installed refrigerator may take 12 to 24 hours to begin making ice cubes.

You will hear a buzzing sound each time the icemaker fills with water.

Throw away the first few batches of ice to allow the water line to clear.

Be sure nothing interferes with the sweep of the feeler arm.

When the bin fills to the level of the feeler arm, the icemaker will stop producing ice.

It is normal for several cubes to be joined together.

If ice is not used frequently, old ice cubes will become cloudy, taste stale and shrink.

Preparing for Vacation

Set the icemaker power switch to **OFF** and shut off the water supply to the refrigerator.

If the temperature can drop below freezing, have a qualified servicer drain the water supply system (on some models) to prevent serious property damage due to flooding.

When you should set the icemaker power switch to OFF

- When the ice storage bin is removed for more than a minute or two.
- When the refrigerator will not be used for several days.
- When the water supply will be shut off for several hours.

Normal sounds you may hear

- The icemaker water valve will buzz when the icemaker fills with water. If the power switch is in the **ON** position, it will buzz even if it has not yet been hooked up to water. Keeping the power switch in the **ON** position before it is hooked up to water can damage the icemaker. To prevent this, move the power switch to the **OFF** position. This will stop the buzzing.
- The sound of cubes dropping into the bin and water running in the pipes as the icemaker refills.

Before you call for service...



Troubleshooting Tips
 Save time and money! Review the following chart first and you may not need to call for service.

Problem	Possible Causes	What To Do
Automatic icemaker does not work	Freezer compartment too warm.	<ul style="list-style-type: none"> After installing the kit, allow the refrigerator to completely cool down for 24 hours. Once the compartment is cool, the icemaker will begin ice production.
	Icemaker is not turned on.	<ul style="list-style-type: none"> Move the icemaker power switch to the ON position.
	Icemaker is not plugged in correctly.	<ul style="list-style-type: none"> Check that the icemaker cord plug is fully inserted into the socket. See <i>Plug in the icemaker</i>.
	Water line kinked.	<ul style="list-style-type: none"> Check that the plastic water line running from the valve to the water tube inlet is not kinked. See <i>Connect the water line</i>. A kink in the water line will restrict flow to the water line.
	Water supply turned off or not connected.	<ul style="list-style-type: none"> After installing the kit, make sure the house water supply to the refrigerator has been turned on.
	Piled up cubes in the storage bin cause the icemaker to shut off.	<ul style="list-style-type: none"> Level cubes by hand.
	Water valve is not plugged in correctly.	<ul style="list-style-type: none"> Check that the valve wire adapter is completely plugged onto the terminals on the water valve. See <i>Attach the water valve</i>.

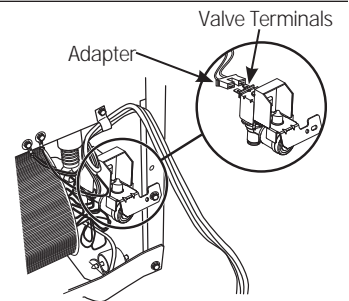
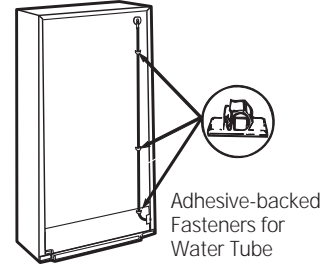
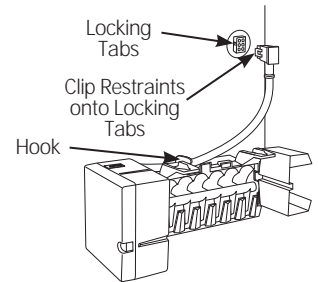
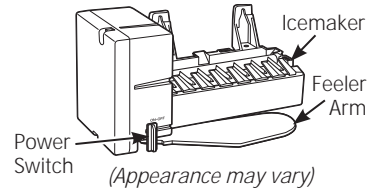

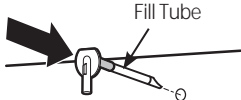
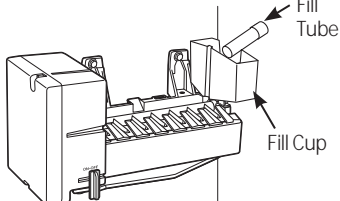
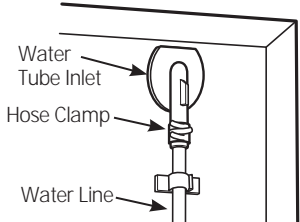
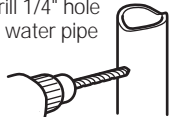
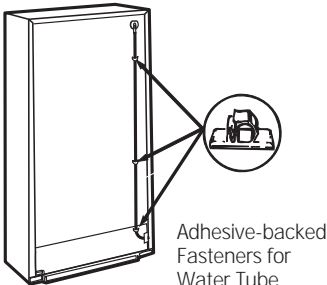
Problem	Possible Causes	What To Do
<p><i>Leaking water around the fill cup</i></p>	<p>Foam in the fill cup from installing the fill tube.</p>	<ul style="list-style-type: none"> If the fill tube was installed by sliding it through the back of the refrigerator, it may have picked up pieces of foam as it was pushed through. This foam can interfere with the water flow in the fill cup. Check the cup and make sure there are no foam pieces. 
	<p>Fill tube not correctly seated in the fill cup.</p>	<ul style="list-style-type: none"> Check that the fill tube is correctly inserted in the fill cup opening. See <i>Mount the icemaker</i>. 
<p><i>Leaking water behind the refrigerator</i></p>	<p>House supply not properly connected to the water valve.</p>	<ul style="list-style-type: none"> Check that the house supply is firmly attached to the water valve. See <i>Water line installation instructions</i>.
	<p>Water line not connected to the water tube inlet.</p>	<ul style="list-style-type: none"> Check that the plastic water line running from the valve to the water tube inlet is firmly attached with the hose clamp. See <i>Connect the water line</i>. 
<p><i>Slow ice/freezer not cold enough</i></p>	<p>Door left open.</p>	<ul style="list-style-type: none"> Check to see if package is holding door open.
	<p>Temperature control not set cold enough.</p>	<ul style="list-style-type: none"> See <i>About the Temperature Control</i> in the Owner's Manual of the refrigerator.
<p><i>Ice cubes too small/slow ice</i></p>	<p>Water shutoff valve connecting refrigerator to house water line may be clogged.</p>	<ul style="list-style-type: none"> We recommend drilling a 1/4" hole in the water pipe to connect the water shut-off valve. Failure to drill a 1/4" hole may result in reduced ice production or smaller cubes. See <i>Installing the water line</i>. 
	<p>Water line kinked.</p>	<ul style="list-style-type: none"> Check that the plastic water line running from the valve to the water tube inlet is not kinked. See <i>Connect the water line</i>. A kink in the water line will restrict flow to the icemaker. 

Before you call for service...



Troubleshooting Tips
Save time and money! Review the following chart first and you may not need to call for service.

<i>Problem</i>	<i>Possible Causes</i>	<i>What To Do</i>
<i>Ice cubes not landing in bucket</i>	Icemaker cord causing icemaker/bucket misalignment	<ul style="list-style-type: none">• Be sure icemaker power cord is in the hook as stated in <i>Step 8</i> in Installation Instructions.
<i>Ice cubes have odor/taste</i>	Ice storage bin needs cleaning.	<ul style="list-style-type: none">• Empty and wash bin. Discard old cubes.
	Food transmitting odor/taste to ice cubes.	<ul style="list-style-type: none">• Wrap foods well.
	Interior of refrigerator needs cleaning.	<ul style="list-style-type: none">• See <i>Care and cleaning</i> in the Owner's Manual of the refrigerator.
<i>Frequent "buzzing" sound</i>	Normal operation.	<ul style="list-style-type: none">• During normal operation, the water valve will "buzz" when the icemaker fills with water.

Installation Instructions

IM-4D Icemaker Kit

*Questions? Call 800.GE.CARES (800.432.2737) or Visit our Website at: GEAppliances.com
In Canada, call 1.800.561.3344 or Visit our Website at: geappliances.ca*

BEFORE YOU BEGIN

Read these instructions completely and carefully.

- **IMPORTANT** – Save these instructions for local inspector's use.
- **IMPORTANT** – Observe all governing codes and ordinances.
- **Note to Installer** – Be sure to leave these instructions with the Consumer.
- **Note to Consumer** – Keep these instructions for future reference.
- **Skill level** – Installation of this appliance requires basic mechanical and electrical skills.
- **Completion time** – 20–60 minutes
- Proper installation is the responsibility of the installer.
- Product failure due to improper installation is not covered under the Warranty.

ARE YOU REPLACING AN ICEMAKER WITH THIS KIT?

It's important that you use the water valve and fill tube assembly that come with this kit, even though your refrigerator may already have them installed.

The old valve will not allow enough water through to fill the icemaker properly and will cause damage.

DAMAGE – SHIPMENT/INSTALLATION

- **If the unit is damaged in shipment**, return the unit to the store in which it was bought for repair or replacement.
- **If the unit is damaged by the customer**, repair or replacement is the responsibility of the customer.
- **If the unit is damaged by the installer** (if other than the customer), repair or replacement must be made by arrangement between customer and installer.

Installation Instructions

CONTENTS OF KIT IM-4D

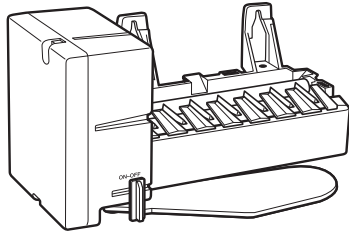

① Icemaker
(Appearance may vary)



② Installation Instructions

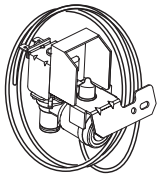

③ Water Valve and
Tube Assembly



④ Adhesive-Backed Water Tube
Fasteners, to secure plastic
water tube (4)



⑤ Hex-Head Screw
for Water Line Clamp (3/4")*



⑥ Water Line Clamp
(strain relief), for house
water line



⑦ Warranty Label

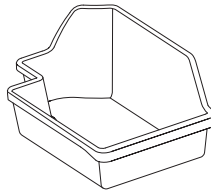

⑧ Ice Bucket



⑨ Hex-Head Screw, for
attaching water valve (3/8")*



⑩ Phillips Head Screws,
for mounting icemaker (2)
(7/8")*

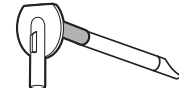

⑪ Short (~8") Fill tube Assembly

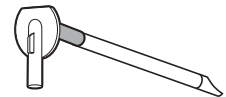

⑫ Long (~9") Fill tube Assembly

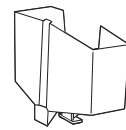

⑬ Icemaker Fill Cup
(side-mounted)



⑭ Hose Clamp



⑮ Hex-Head Screws, for
attaching water tube
inlet cover (2) (5/8")*

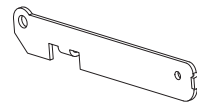

⑯ Bracket Extension



⑰ Hex-Head Screws, for
bracket extension (1)
(1/4")*

*NOTE: Screw lengths are the lengths of the threaded portion of the screw, not including the head.

Installation Instructions

ICEMAKER INSTALLATION INSTRUCTIONS **U** **V** OR **W**

Are these the right instructions for your model? Follow the Installation Instructions indicated by the label on the back of the refrigerator—**U** **V** or **W**. For letter **T**, go to page 12 for instructions.

BEFORE YOU BEGIN

Read each step thoroughly before proceeding.

-  **WARNING** To eliminate the risk of electric shock or injury during installation, you must first unplug the refrigerator before proceeding. Failure to follow these instructions can result in electrical shock.



TOOLS YOU WILL NEED



Flat blade and Phillips screwdrivers



Pliers



Sharp knife

1 SELECT FILL TUBE FOR YOUR REFRIGERATOR

Which fill tube should you use?

There is a label on the back of the refrigerator that will tell you which to use: **U** **V** or **W**

The fill tube you use will depend on the model and size of your refrigerator.

For letter **U**:

Use long fill tube assembly #12 and cut off 1/2" of length from the tip of the fill tube. This will ensure the correct length fill tube for your model. This will provide proper water flow into your fill cup and icemaker. It will prevent the fill tube from freezing up with water and ice.

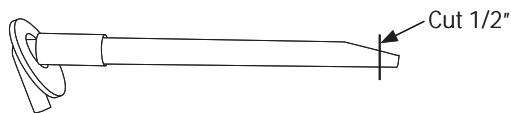

For letter **V**:

It is important to use the correct fill tube assembly because the length is critical to the performance of your icemaker. It is also critical to prevent any leaking from the fill tube into the freezer itself.

- Open the fresh food door and locate the label in the **upper left** corner of the compartment.
- Find the model number in bold listed under **MODEL NO.**
- Match the two digit number in the model number to the fill tube number in the table below. NOTE: The desired number starts at the fourth character.

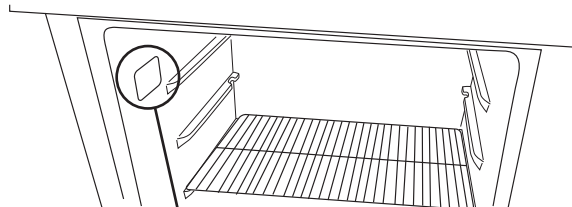

Model Number

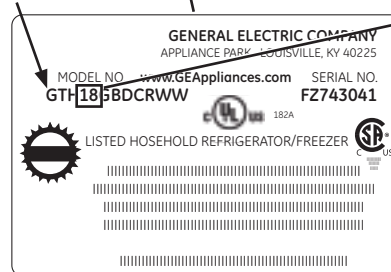

Model Number	Fill Tube
12	# 12
15	# 11
16	# 11
18	# 12
21	# 12

For letter **W**:

Use short fill tube assembly #11 and cut off 1" of length from the tip of the fill tube. This will ensure the correct length fill tube for your model. This will provide proper water flow into your fill cup and icemaker. It will prevent the fill tube from freezing up with water and ice.

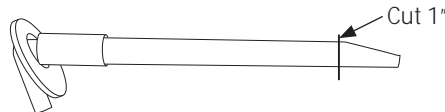

2 REPOSITION FREEZER SHELF

- Make sure the freezer shelf is in the lowest position.

Installation Instructions

ICEMAKER INSTALLATION INSTRUCTIONS (CONT.)

3 REMOVE THE OUTLET COVER

Peel off the outlet cover.

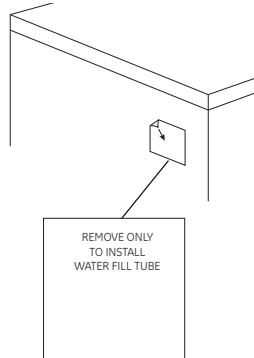

6 SET POWER SWITCH TO OFF

Set the icemaker power switch to **OFF**. Leave the power switch in the **OFF** position until the refrigerator is connected to the water supply to prevent premature operation.

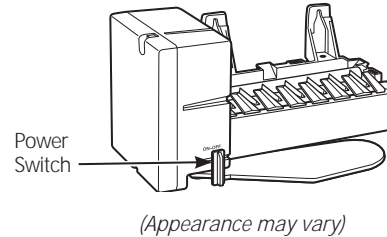

4 INSTALL FILL TUBE

Go to the back of the refrigerator. On the refrigerator side of the **fill tube assembly** (11 or 12 depending on model), there is an adhesive backing. Remove the adhesive backing and slide the tube into the hole near the top at the back of the refrigerator. Firmly press on the fill tube assembly to secure it to the refrigerator.

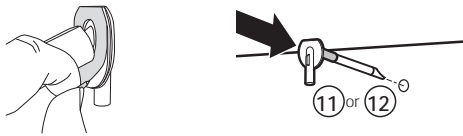

7 INSTALL THE ICEMAKER FILL CUP

For letters **U** & **V** :

Install the **icemaker fill cup** (13) into the icemaker as shown.

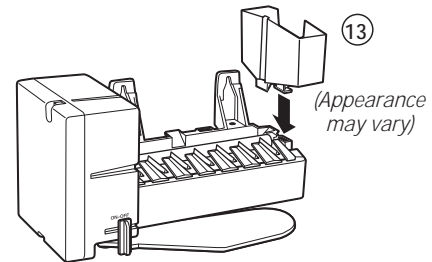

For letter **W** :

Install the **icemaker fill cup** that came with your refrigerator into the icemaker as shown. If the fill cup has been misplaced, call 1.800.626.2002 and order part WR29X10074. If the correct fill cup is not installed into the icemaker, there is the possibility of water leaking into the freezer and not into the icemaker.

5 PREPARE FOR INSTALLATION

Inside the freezer, loosen the two **mounting screws** (B) but do not screw them all the way out. Your model may have screws already installed; if not, remove the 2 plug buttons and insert the 2 **Phillips head screws** (10). The screws should extend approximately 1/2" (13 mm) out from the freezer wall.

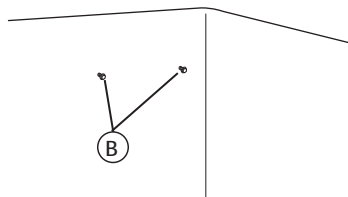

8 PLUG IN THE ICEMAKER

Holding the icemaker in place, insert the **icemaker power cord plug** into the socket on the side wall, making sure the prongs and holes are matched. Press the plug firmly into the socket. Lock the plug in place by clipping the restraints onto each side of the plug.

Make sure the restraints click into place. Make sure the power cord is still in the hook on the back of the icemaker.

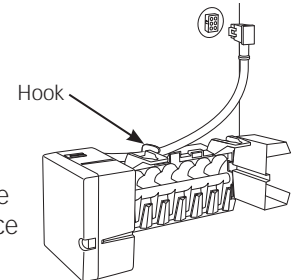

Installation Instructions

9 MOUNT THE ICEMAKER

- Lift the icemaker so the **fill tube assembly** (11 or 12 depending on model) fits in the **fill cup opening** (D). Hang the icemaker on the **two mounting screws** (B).

Make sure:

- The **power cord** is still firmly in the socket.
- The **fill tube assembly** (11 or 12 depending on model) extends into the fill cup opening at the back of the icemaker. (Check the rear of the refrigerator to make sure the fill tube has not been pushed out of the back of the refrigerator).
- The icemaker mounting screws are located in the uppermost position of the mounting slots on the icemaker bracket.
- The icemaker is level.
- The icemaker power switch is in the **OFF** position.

SECURELY TIGHTEN THE ICEMAKER MOUNTING SCREWS.

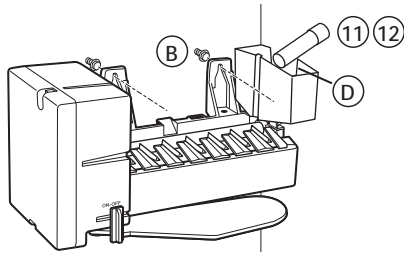

11 ATTACH WARRANTY LABEL

A **label** (7) is provided with this kit to record the date of installation for warranty purposes. Apply it to the back of the refrigerator.

12 KEEP THIS MANUAL

The **warranty** for the icemaker is printed in this manual. **Keep this manual with your Refrigerator Owner's Manual.**

The icemaker installation inside the freezer is now complete. Continue to the *Water Valve Assembly* section on page 14.

10 INSTALL THE ICE BUCKET

Place the **ice bucket** (8) under the icemaker.

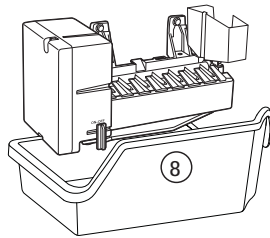

Installation Instructions

ICEMAKER INSTALLATION INSTRUCTIONS T

BEFORE YOU BEGIN

Read each step thoroughly before proceeding.

- ⚠ WARNING** To eliminate the risk of electric shock or injury during installation, you must first unplug the refrigerator before proceeding. Failure to follow these instructions can result in electrical shock.



TOOLS YOU WILL NEED



Flat blade and Phillips screwdrivers



Pliers



Sharp knife

1 PREPARE FOR INSTALLATION

- Remove the storage basket (on some models) by pulling it out to the stop position and lifting it up and out.

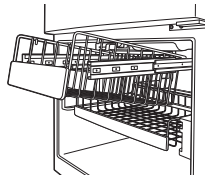

Note: After removing the basket, push the extension arms back into the freezer compartment.

- Remove the chiller shelf (on some models) by pulling it straight out.

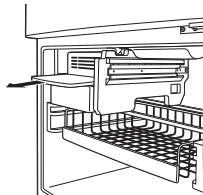

- Remove the center vertical shelf support (on some models) by lifting it and rotating its bottom to the right.

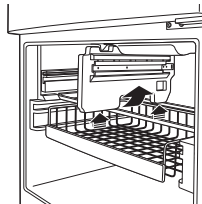

- Inside the freezer, remove the two small white plug buttons (on some models) from the side wall. (If screws are present instead of plugs, leave them in place.)

Remove side wall plug buttons or leave screws in place

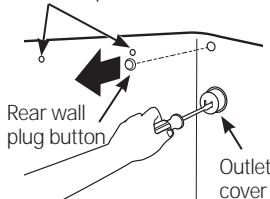

- Remove and discard the large white plug from the rear freezer wall.

- Remove the outlet cover with a flat-blade screwdriver.

2 SET POWER SWITCH TO OFF

Set the icemaker power switch to **OFF**. Leave the power switch in the **OFF** position until the refrigerator is connected to the water supply to prevent premature operation.

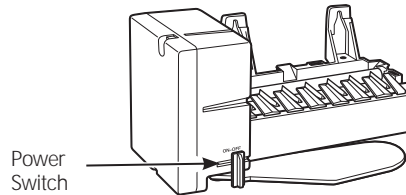

(Appearance may vary)

3 INSTALL THE MOUNTING SCREWS

- Skip to Step 4 if screws are already in place in the freezer side wall.
- Install two self-tapping **Phillips head screws** (10) from the kit in the holes in the side wall. The screw heads should extend about 1/2" (13 mm) from the side wall.

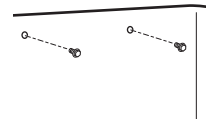

4 INSTALL THE ICEMAKER FILL CUP

Install the icemaker fill cup (end-mounted) that came with your unit into the icemaker as shown. If the fill cup has been misplaced, call 1.800.626.2002 and order part WR29X10092.

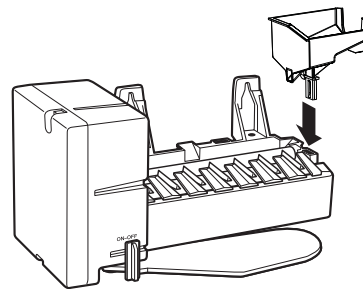

Installation Instructions

5 PLUG IN THE ICEMAKER

Holding the icemaker in place, insert the icemaker power cord plug into the socket on the side wall, making sure the prongs and holes are matched. Press the plug firmly into the socket. Lock the plug in place by clipping the restraints onto each side of the plug. Make sure the restraints click into place and the power cord is still in the hook on the back of the icemaker.

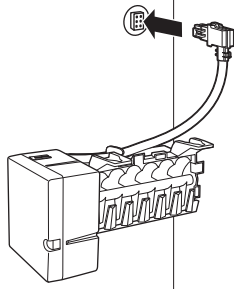

6 MOUNT THE ICEMAKER

- Lift the icemaker so the **fill tube** that was already installed in the refrigerator fits in the **fill cup opening**. Hang the **icemaker** on the two **mounting screws** in the side wall.

Make sure:

- The **power cord** is still firmly in the socket.
- The **fill tube** extends into the fill cup opening on the back of the icemaker. (Check the rear of the refrigerator to make sure the fill tube has not been pushed out of the back of the refrigerator).
- The icemaker mounting screws are located in the uppermost position of the mounting slots on the icemaker bracket.
- The icemaker is level.
- The icemaker power switch is set to **OFF**.

THEN SECURELY TIGHTEN THE ICEMAKER MOUNTING SCREWS.

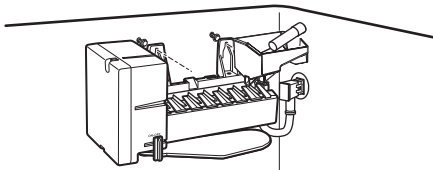

7 RE-INSTALL THE SHELF SUPPORT, BUCKET, SHELF AND BASKET

Replace the center vertical shelf support, ice bucket, chiller shelf and storage basket by reversing the steps in Step 1.

8 ATTACH WARRANTY LABEL

A **label (7)** is provided with this kit to record the date of installation for warranty purposes. Apply it to the back of the refrigerator.

9 KEEP THIS MANUAL

The warranty for the icemaker is printed in this manual. Keep this manual with your Refrigerator Owner's Manual.

The icemaker installation inside the freezer is now complete. Continue to the *Water Valve Assembly* section on page 16.

Installation Instructions

WATER VALVE ASSEMBLY INSTALLATION INSTRUCTIONS **U** **V** OR **W**

Are these the right instructions for your model? Follow the Installation Instructions indicated by the label on the back of the refrigerator—**U** **V** or **W**. For letter **T**, go to page 16 for instructions.

BEFORE YOU BEGIN

Read each step thoroughly before proceeding.

- **⚠ WARNING** To eliminate the risk of electric shock or injury during installation, you must first unplug the refrigerator before proceeding. Failure to follow these instructions can result in electrical shock.



TOOLS YOU WILL NEED



Flat blade and Phillips screwdrivers



Pliers



Sharp knife



1/4" and 5/16" Nutdrivers

1 REMOVE THE COVER

Remove the compressor compartment access cover. This requires removing screws which attach the cover to the back of the refrigerator case.

Be sure to save the screws as the access cover must be reinstalled later to ensure your refrigerator will function properly.

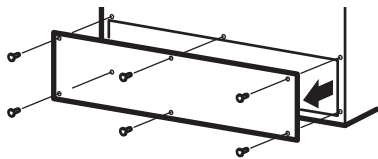

2 ATTACH THE WATER VALVE

- Locate the female connector plug. Plug the **female connector (C)** onto the **male terminals on the water valve (3)**. Either wire can go on either terminal.

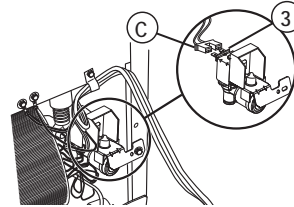

- Fasten the water valve to the cabinet by driving the **hex-head screw (9)** from the kit into the hole in the cabinet leg.

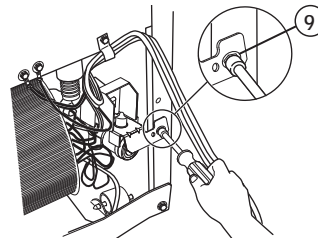

3 CONNECT WATER TUBE TO INLET

- Squeeze the ends of the **hose clamp (14)** from the kit with pliers and slide the clamp over the fill tube assembly, located in the top right corner of the refrigerator.
- While still squeezing the clamp, insert the free end of the **water tube (3)** into the fill tube assembly as far as it will go.
- Then slide the clamp downward to capture the water tube in place.
- Using one of the **adhesive-backed fasteners (4)**, secure the water tube to the back of the refrigerator about 1/2" below the inlet.
- If the water tube is not pushed in as far as it can go and the hose clamp is not in place over the fill tube assembly, then leaks are possible.

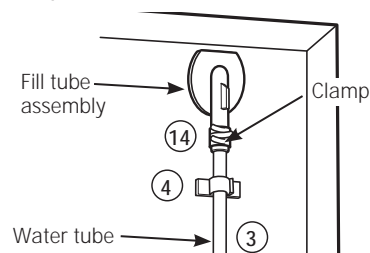

Installation Instructions

4 INSTALL WATER LINE CLAMP

- Attach the **metal water line clamp (strain relief)** (6) to the refrigerator. Drive the **screw** (5) from the kit through the **clamp** (6) at the small indent into the back of the cabinet.
- The metal clamp is for the house water line (see the Water Line Installation Instructions). It is not to be used for the water tube from the water valve up to the inlet.

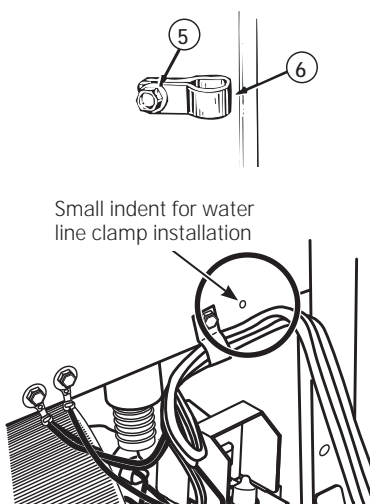

6 WATER VALVE INSTALLED

Refer to the *Water Line Installation Instructions* for connection to the home water supply. After water line installation is completed, set the **icemaker power switch** to **ON**.

The icemaking cycle will not begin until the icemaker and freezer compartment reach operating temperature, then icemaking will begin automatically.

7 REINSTALL THE COVER

Reinstall the compressor compartment access cover. This requires using the screws you removed previously to reattach the cover to the back of the refrigerator case. This must be reinstalled for your refrigerator to function properly.

5 ROUTE AND ATTACH THE WATER TUBE

- Fasten the plastic water tube to the back of the refrigerator with **adhesive-backed fasteners** (4), spacing the fasteners as shown to take up slack in the tube.

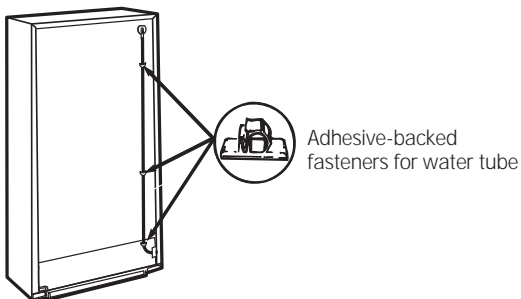

Installation Instructions

WATER VALVE ASSEMBLY INSTALLATION INSTRUCTIONS T

BEFORE YOU BEGIN

Read each step thoroughly before proceeding.

- **⚠ WARNING** To eliminate the risk of electric shock or injury during installation, you must first unplug the refrigerator before proceeding. Failure to follow these instructions can result in electrical shock.



TOOLS YOU WILL NEED



Flat blade and Phillips screwdrivers



Pliers

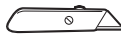

Sharp knife



1/4" and 5/16" Nutdrivers

1 REMOVE THE COVER

Use a 5/16" nutdriver or an adjustable wrench to remove the compressor compartment access cover. This requires removing six screws which attach the cover to the back of the refrigerator case.

Be sure to save the screws as the access cover must be reinstalled later to ensure your refrigerator will function properly.

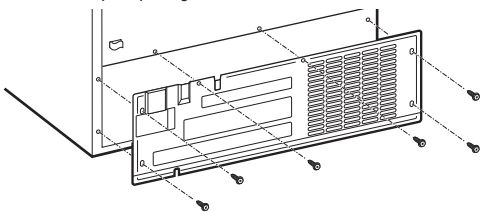

2 PLASTIC WATER TUBING

- Remove water line from the valve assembly (3) included in this kit by removing the tube from the clip and pushing on the bottom of the valve quick-connect, disengaging the tube and pulling it from the valve.

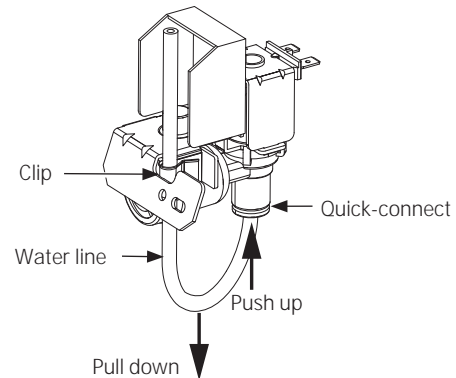

- Use the water line from the fill tube assembly that came with the refrigerator. The water line is attached to the fill tube assembly that is already installed in the refrigerator. Remove the plug from the end of the waterline. Route the water line through the clip on the valve pushing it into the quick-connect on the valve. The white line will be barely visible if properly engaged.

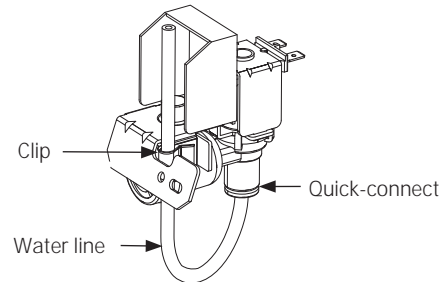

3 ATTACH THE BRACKET EXTENSION TO THE WATER VALVE

- Use a 1/4" nutdriver to attach the bracket extension (16) to the water valve bracket with the screw (17).

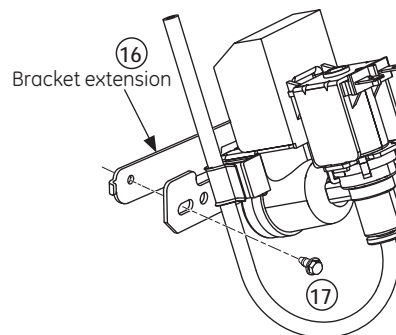

Installation Instructions

4 ATTACH THE WATER VALVE TO THE MACHINE COMPARTMENT

- Locate the female connector plug. Plug the female connector onto the male terminals on the water valve. Either wire can go on either terminal.

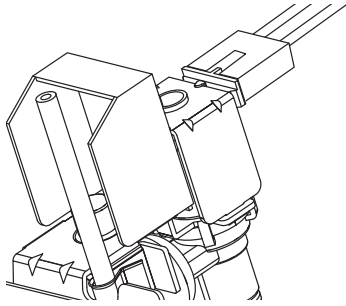

- Fasten the water valve to the cabinet by driving the **hex-head screw (9)** from the kit through the hole in the bracket extension and into the hole in the cabinet.

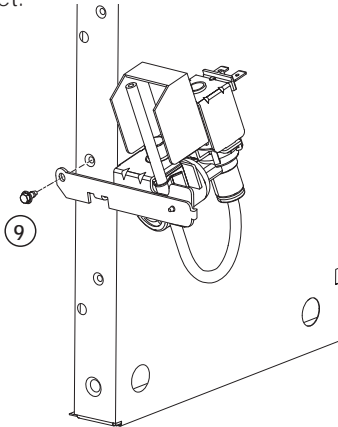

5 INSTALL WATER LINE CLAMP

- Attach the **water line clamp (6)** (strain relief) from the kit to the refrigerator. With the clamp directly in line with the water valve, drive the **screw (5)** from the kit through the **clamp** at the indent into the back of the cabinet.

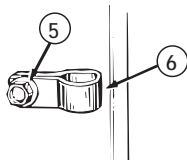

- The metal clamp is for the house water line (see Water Line Installation Instructions). It is not to be used for the tubing from the water valve up to the icemaker.

6 ROUTE AND ATTACH THE PLASTIC WATER LINE

- Fasten the plastic water line to the back of the cabinet with **adhesive-backed fasteners (4)**.

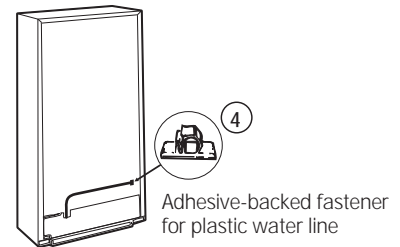

7 WATER VALVE INSTALLED

Refer to the Water Line Installation Instructions for connection to the home water supply. After water line installation is completed, set the **icemaker power switch** to **ON**.

The icemaking cycle will not begin until the icemaker and freezer compartment reach operating temperature, then icemaking will begin automatically.

8 REINSTALL THE COVER

Reinstall the compressor compartment access cover. This requires using the screws you removed previously to reattach the cover to the back of the refrigerator case. This must be reinstalled for your refrigerator to function properly.

Installation Instructions

INSTALLING THE WATER LINE

BEFORE YOU BEGIN

Recommended copper water supply kits are WX8X2, WX8X3 or WX8X4, depending on the amount of tubing you need. Approved plastic water supply lines are SmartConnect™ Refrigerator Tubing (WX08X10002, WX08X10006, WX08X10015 and WX08X10025).

When connecting your refrigerator to a GE Appliances Reverse Osmosis Water System, the only approved installation is with a GE Appliances RVKit. For other reverse osmosis water systems, follow the manufacturer's recommendations.

If the water supply to the refrigerator is from a Reverse Osmosis Water Filtration System AND the refrigerator also has a water filter, use the refrigerator's filter bypass plug. Using the refrigerator's water filtration cartridge in conjunction with the RO filter can result in hollow ice cubes and slower water flow from the water dispenser.

This water line installation is not warranted by the refrigerator or icemaker manufacturer. Follow these instructions carefully to minimize the risk of expensive water damage.

Water hammer (water banging in the pipes) in house plumbing can cause damage to refrigerator parts and lead to water leakage or flooding. Call a qualified plumber to correct water hammer before installing the water supply line to the refrigerator.

To prevent burns and product damage, do not hook up the water line to the hot water line.

If you use your refrigerator before connecting the water line, make sure the icemaker power switch is in the **OFF** position.

Do not install the icemaker tubing in areas where temperatures fall below freezing.

When using any electrical device (such as a power drill) during installation, be sure the device is double insulated or grounded in a manner to prevent the hazard of electric shock, or is battery powered.

All installations must be in accordance with local plumbing code requirements.



WARNING

Connect to potable water supply only.

WHAT YOU WILL NEED

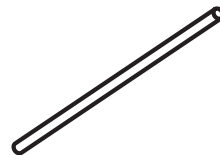

- **Copper or SmartConnect™ Refrigerator Tubing kit**, 1/4" outer diameter to connect the refrigerator to the water supply. If using copper, be sure both ends of the tubing are cut square.

To determine how much tubing you need: measure the distance from the water valve on the back of the refrigerator to the water supply pipe. Then add 8 feet (2.4 m). Be sure there is sufficient extra tubing (about 8 feet [2.4 m] coiled into 3 turns of about 10" [25 cm] diameter) to allow the refrigerator to move out from the wall after installation.

SmartConnect™ Refrigerator Tubing Kits are available in the following lengths:

2' (0.6 m)	- WX08X10002
8' (2.4 m)	- WX08X10006
15' (4.6 m)	- WX08X10015
25' (7.6 m)	- WX08X10025

Be sure that the kit you select allows at least 8 feet (2.4 m) as described above.

NOTE: The only GE Appliances approved plastic tubing is that supplied in SmartConnect™ Refrigerator Tubing kits. Do not use any other plastic water supply line because the line is under pressure at all times. Certain types of plastic will crack or rupture with age and cause water damage to your home.

- **A GE Appliances water supply kit** (containing tubing, shutoff valve and fittings listed below) is available at extra cost from your dealer or from Parts and Accessories, 877.959.8688.
- **A cold water supply.** The water pressure must be between 20 and 120 p.s.i. (1.4–8.2 bar) on models without a water filter and between 40 and 120 p.s.i. (2.8–8.2 bar) on models with a water filter.

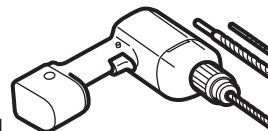

- Power drill.
- 1/2" or adjustable wrench.
- Straight and Phillips blade screwdriver.

Installation Instructions

WHAT YOU WILL NEED (CONT.)

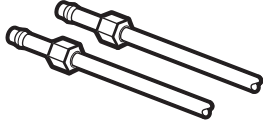

- Two 1/4" outer diameter compression nuts and 2 ferrules (sleeves)—to connect the copper tubing to the shutoff valve and the refrigerator water valve.

OR

- If you are using a SmartConnect™ Refrigerator Tubing kit, the necessary fittings are preassembled to the tubing.

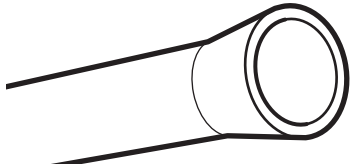

- If your existing copper water line has a flared fitting at the end, you will need an **adapter** (available at plumbing supply stores) to connect the water line to the refrigerator **OR** you can cut off the flared fitting with a **tube cutter** and then use a compression fitting. Do not cut formed end from SmartConnect™ Refrigerator tubing.

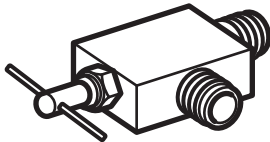

- **Shutoff valve** to connect to the cold water line. The shutoff valve should have a water inlet with a minimum inside diameter of 5/32" at the point of connection to the **COLD WATER LINE**. Saddle-type shutoff valves are included in many water supply kits. Before purchasing, make sure a saddle-type valve complies with your local plumbing codes.

Install the shutoff valve on the nearest frequently used drinking water line.

1 SHUT OFF THE MAIN WATER SUPPLY

Turn on the nearest faucet long enough to clear the line of water.

2 CHOOSE THE VALVE LOCATION

Choose a location for the valve that is easily accessible. It is best to connect into the side of a vertical water pipe. When it is necessary to connect into a horizontal water pipe, make the connection to the top or side, rather than at the bottom, to avoid drawing off any sediment from the water pipe.

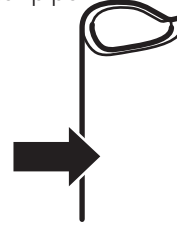

3 DRILL THE HOLE FOR THE VALVE

Drill a 1/4" hole in the water pipe (even if using a self-piercing valve) using a sharp bit. Remove any burrs resulting from drilling the hole in the pipe. **Take care not to allow water to drain into the drill.** Failure to drill a 1/4" hole may result in reduced ice production or smaller cubes.

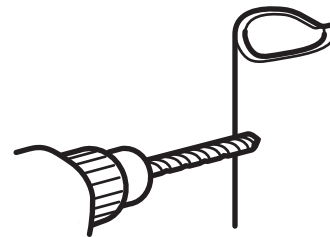

4 FASTEN THE SHUTOFF VALVE

Fasten the shutoff valve to the cold water pipe with the pipe clamp.

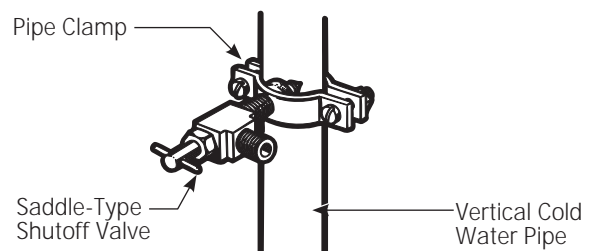

NOTE: Commonwealth of Massachusetts Plumbing Codes 248CMR shall be adhered to. Saddle valves are illegal and use is not permitted in Massachusetts. Consult with your licensed plumber.

Installation Instructions

INSTALLING THE WATER LINE (CONT.)

5 TIGHTEN THE PIPE CLAMP

Tighten the clamp screws until the sealing washer begins to swell.

NOTE: Do not overtighten or you may crush the tubing.

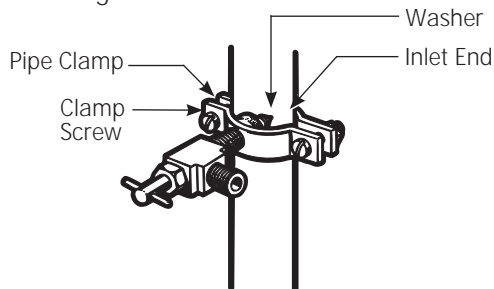

NOTE: Commonwealth of Massachusetts Plumbing Codes 248CMR shall be adhered to. Saddle valves are illegal and use is not permitted in Massachusetts. Consult with your licensed plumber.

8 FLUSH OUT THE TUBING

Turn the main water supply on and flush out the tubing until the water is clear.

Shut the water off at the water valve after about one quart (1 liter) of water has been flushed through the tubing.



6 ROUTE THE TUBING

Route the tubing between the cold water line and the refrigerator.

Route the tubing through a hole drilled in the wall or floor (behind the refrigerator or adjacent base cabinet) as close to the wall as possible.

NOTE: Be sure there is sufficient extra tubing (about 8 feet [244 cm] coiled into 3 turns of about 10" [25 cm] diameter) to allow the refrigerator to move out from the wall after installation.

9 CONNECT THE TUBING TO THE REFRIGERATOR

NOTES:

- Before making the connection to the refrigerator, be sure the refrigerator power cord is not plugged into the wall outlet.
- If your refrigerator does not have a water filter, we recommend installing one if your water supply has sand or particles that could clog the screen of the refrigerator's water valve. Install it in the water line near the refrigerator. If using SmartConnect™ Refrigerator Tubing kit, you will need an additional tube (WX08X10002) to connect the filter. Do not cut plastic tube to install filter.

Remove the plastic flexible cap from the water valve (refrigerator connection).

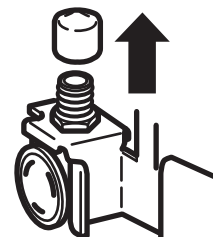

7 CONNECT THE TUBING TO THE VALVE

Place the compression nut and ferrule (sleeve) for copper tubing onto the end of the tubing and connect it to the shutoff valve.

Make sure the tubing is fully inserted into the valve. Tighten the compression nut securely.

For plastic tubing from a SmartConnect™ Refrigerator Tubing kit, insert the molded end of the tubing into the shutoff valve and tighten compression nut until it is hand tight, then tighten one additional turn with a wrench. Overtightening may cause leaks.

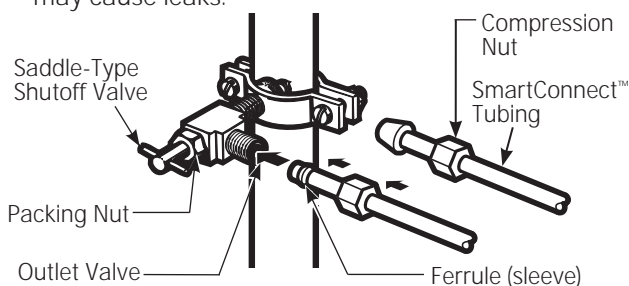

Installation Instructions

9 CONNECT THE TUBING TO THE REFRIGERATOR (CONT.)

Place the compression nut and ferrule (sleeve) onto the end of the tubing as shown. On SmartConnect™ Refrigerator Tubing kit, the nuts are already assembled to the tubing.

Insert the end of the tubing into the water valve connection as far as possible. While holding the tubing, tighten the fitting.

For plastic tubing from a SmartConnect Refrigerator Tubing kit, insert the molded end of the tubing into the refrigerator connection and tighten compression nut until it is hand tight, then tighten one additional turn with a wrench. Overtightening may cause leaks.

Fasten the tubing into the clamp provided to hold it in a vertical position. You may need to pry open the clamp.

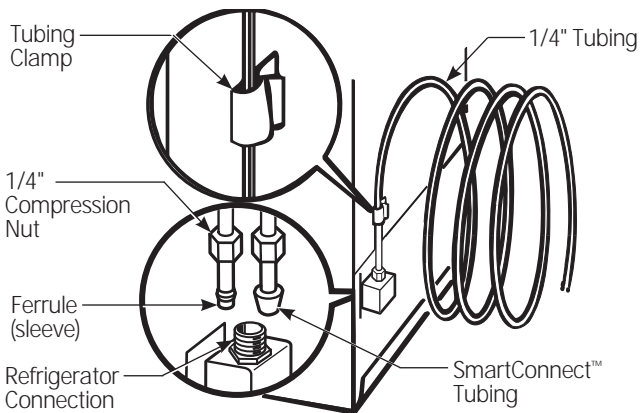

10 TURN THE WATER ON AT THE SHUTOFF VALVE

Tighten any connections that leak.

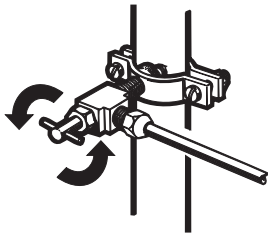

Reattach the compressor compartment access cover.

11 INSTALLING THE REFRIGERATOR

Plug in the refrigerator.

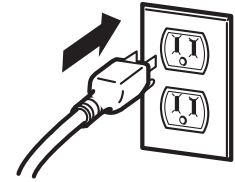

Arrange the coil of tubing so that it does not vibrate against the back of the refrigerator or against the wall. Push the refrigerator back to the wall.

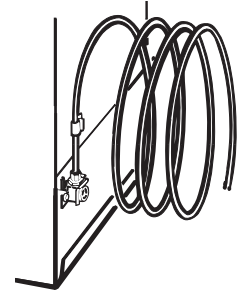

12 START THE ICEMAKER

Set the icemaker power switch to the **ON** position. The icemaker will not begin to operate until it reaches its operating temperature of 15°F (-9°C) or below. It will then begin operation automatically if the icemaker power switch is in the **ON** position.

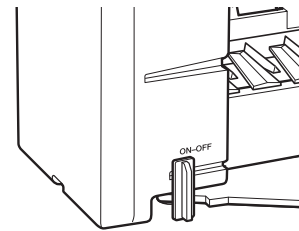

Icemaker Warranty.



All warranty service provided by our Factory Service Centers, or an authorized Customer Care® technician. To schedule service, on-line, visit us at GEAppliances.com, or call 800.GE.CARES (800.432.2737). In Canada, call 1.800.561.3344. Please have serial number and model number available when calling for service.

Staple your receipt here.
Proof of the original purchase date is needed to obtain service under the warranty.

For The Period Of:	We Will Replace:
--------------------	------------------

<p>One Year From the date of the original purchase</p>	<p>Any part of the icemaker which fails due to a defect in materials or workmanship. During this limited one-year warranty, GE Appliances will provide, free of charge, replacement parts for any defective part in your icemaker kit.</p>
---	---

What Is Not Covered (for customers in the United States):

- Service trips to your home to teach you how to use the product.
- Improper installation.
You are responsible for providing adequate electrical, plumbing, and other connecting facilities, including the water line to the icemaker and the water line installation.
- Failure of the product if it is abused, misused, or used for other than the intended purpose or used commercially.
- Replacement of house fuses or resetting of circuit breakers.
- Damage to the product caused by accident, fire, floods or acts of God.
- Incidental or consequential damage caused by possible defects with this appliance.
- Product not accessible to provide required service.

EXCLUSION OF IMPLIED WARRANTIES—Your sole and exclusive remedy is product repair as provided in this Limited Warranty. Any implied warranties, including the implied warranties of merchantability or fitness for a particular purpose, are limited to one year or the shortest period allowed by law.

This warranty is extended to the original purchaser and any succeeding owner for products purchased for home use within the USA. If the product is located in an area where service by a GE Appliances Authorized Servicer is not available, you may be responsible for a trip charge or you may be required to bring the product to an Authorized GE Appliances Service location for service. In Alaska, the warranty excludes the cost of shipping or service calls to your home.

Some states do not allow the exclusion or limitation of incidental or consequential damages. This warranty gives you specific legal rights, and you may also have other rights which vary from state to state. To know what your legal rights are, consult your local or state consumer affairs office or your state's Attorney General.

Warrantor: General Electric Company. Louisville, KY 40225

What Is Not Covered (for customers in Canada):

- Service trips to your home to teach you how to use the product.
Read your Owner's Manual. If you then have any questions about operating the product, please contact your dealer or our Consumer Relations office at:
Manager, Consumer Relations
Mabe Canada Inc.
1 Factory Lane, Suite 310
Moncton, N.B.
E1C 9M3
- Improper installation.
If you have an installation problem, contact your dealer or installer. You are responsible for providing adequate electrical, exhausting and other connecting facilities.
- Replacement of house fuses or resetting of circuit breakers.
- Failure of the product if it is misused, or used for other than the intended purpose or used commercially.
- Damage to product caused by accident, fire, floods or acts of God.

WARRANTOR IS NOT RESPONSIBLE FOR CONSEQUENTIAL DAMAGES.

Warrantor: MABE CANADA INC.

Consumer Support.



GE Appliances Website

In the U.S.: ***GEAppliances.com***

Have a question or need assistance with your appliance? Try the GE Appliances Website 24 hours a day, any day of the year! For greater convenience and faster service, you can now download Owner's Manuals, order parts or even schedule service on-line. **In Canada: www.geappliances.ca**

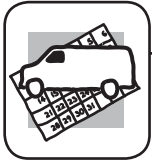

Schedule Service

In the U.S.: ***GEAppliances.com***

Expert GE Appliances repair service is only one step away from your door. Get on-line and schedule your service at your convenience any day of the year! Or call 800.GE.CARES (800.432.2737) during normal business hours.

In Canada, call 1.800.561.3344



Real Life Design Studio

In the U.S.: ***GEAppliances.com***

GE Appliances supports the Universal Design concept—products, services and environments that can be used by people of all ages, sizes and capabilities. We recognize the need to design for a wide range of physical and mental abilities and impairments. For details of GE Appliances Universal Design applications, including kitchen design ideas for people with disabilities, check out our Website today. For the hearing impaired, please call 800.TDD.GEAC (800.833.4322).

In Canada, contact: Manager, Consumer Relations, Mabe Canada Inc.
Suite 310, 1 Factory Lane
Moncton, N.B. E1C 9M3



Extended Warranties

In the U.S.: ***GEAppliances.com***

Purchase a GE Appliances extended warranty and learn about special discounts that are available while your warranty is still in effect. You can purchase it on-line anytime, or call 800.626.2224 during normal business hours. GE Appliances Consumer Home Services will still be there after your warranty expires. **In Canada, call 1.800.290.9029**

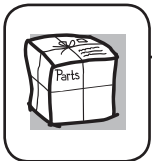

Parts and Accessories

In the U.S.: ***GEAppliances.com***

Individuals qualified to service their own appliances can have parts or accessories sent directly to their homes (VISA, MasterCard and Discover cards are accepted). Order on-line today, 24 hours every day or by phone at 877.959.8688 during normal business hours.

Instructions contained in this manual cover procedures to be performed by any user. Other servicing generally should be referred to qualified service personnel. Caution must be exercised, since improper servicing may cause unsafe operation.

Customers **in Canada** should consult the yellow pages for the nearest Mabe service center, or call 1.800.661.1616.



Contact Us

In the U.S.: ***GEAppliances.com***

If you are not satisfied with the service you receive from GE Appliances, contact us on our Website with all the details including your phone number, or write to:

General Manager, Customer Relations
GE Appliances, Appliance Park
Louisville, KY 40225

In Canada: www.geappliances.ca, or write to: Director, Consumer Relations, Mabe Canada Inc.
Suite 310, 1 Factory Lane
Moncton, N.B. E1C 9M3



Register Your Appliance

In the U.S.: ***GEAppliances.com***

Register your new appliance on-line—at your convenience! Timely product registration will allow for enhanced communication and prompt service under the terms of your warranty, should the need arise. You may also mail in the pre-printed registration card included in the packing material, or detach and use the form in this Owner's Manual. **In Canada: www.geappliances.ca**

Universal Keywords: Div46 Src363 GE General Electric Mechtch

Document Specific Keywords: Instruction Sheet

Date: 102816

Document Name: IM4D

Subject: GE Refrigerator Icemaker Accessory Kit Instruction Sheet

Models: GBE21DSKARSS GBE21DGKARWW GBE21DGKARBB ABE21DGKARBS

ABE21DGKARWS WR29X26688 WR29X10074 WR29X10092 ABE21DGKARBS

ABE21DGKARWS ABE21DGKBS GBE21DGKARBB GBE21DGKARWW

GBE21DSKARSS GTH21GBEBB GTH21GBECC GTH21GCEABB

GTH21GCEAWW GTH21GCEBB GTH21GCEWW GTH21KCWABB

GTH21KCWAWW GTH21KCXABB GTH21KCXACC GTH21KCXAWW

GTH21SCWASS GTH21SCXASS GTL21KCWABS GTL21KCXABS

GTS21KCXABB GTS21KCXAWW GTS21SBXASS GTS21SCXASS

GTZ21GCEASS GTZ21GCEBSS ABE20EGEBRBS ABE20EGEBRWS

ABE20EGHBRBS ABE20EGHBRWS CFCP1NIZASS CFCP1NIZBSS

CFCP1NIZCSS CFCP1NIZDSS CFCP1NIZESS CNE22SSEAFSS

CNS23SSHAFSS CWS21SSEAFSS CWS21SSEBFSS GBE20ESEBRSS

GBE20ETEBRBB GBE20ETEBRCC GBE20ETEBRWW GBS20EGHBRBB

GBS20EGHBRWW GBS20ESHBRSS GBSC0HCXERBB GBSC0HCXERWW

GBSC0HCXFRBB GBSC0HCXFRWW GDSS0KCXFRSS GFCE1NFBADSS

GFCE1NFBEDSS GFCE1NFBFDSS GFSF2HCYHBB GFSF2HCYHWW

GFSF2KEYHBB GFSF2KEYHCC GFSF2KEYHWW GFSL2KEYHLS

GFSS2HCYHSS GFSS2HCYJSS GFSS2KEYHSS GNE22GGEAFBB

GNE22GGEAFWW GNE22GGEBFBB GNE22GGEBFWW GNE22GMEAFES

GNE22GMEBFES GNE22GMECFES GNE22GSEAFSS GNE22GSEBFSS

GNS22ESEAFSS GNS22ESEBFSS GNS23GGHBFBB GNS23GGHBFWW

GNS23GMHBFES GNS23GSHBFSS GTE16DTHBRCC PDCE1NBZCDSS

PDCE1NBZCJSS PDCE1NBZHDSS PDCE1NBZHJSS PDCS1NCZALSS

PDCS1NCZARSS PDCS1NCZBLSS PDCS1NCZBRSS PDCS1NCZCLSS

PDCS1NCZCRSS PDCS1NCZHLSS PDCS1NCZHRSS PDSE5NBZCDSS

PDSE5NBZHDSS PDSS0MFYELSS PDSS0MFYERSS PFCA1NJZADSS

PFCA1NJZBDSS PFCA1NJZCDSS PFCA1NJZHDSS PFCA1NJZIDSS

PFCE1NFZAANB PFCE1NFZBANB PFCE1NFZCANB PFCE1NJYCDSS

PFCE1NJZADSS PFCE1NJZBDSS PFCE1NJZCDSS PFCE1NJZHDSS

PFCF1NFCABB PFCF1NFCAWW PFCF1NFCBBB PFCF1NFCBWW

PFCF1NFZABB PFCF1NFZAWW PFCF1NFZBBB PFCF1NFZBWW

PFCF1NFZCBB PFCF1NFZCWW PFCF1PJZABB PFCF1PJZAWW

PFCF1PJZBBB PFCF1PJZBWW PFCF1PJZCBB PFCF1PJZCWW

PFCS1NFCASS PFCS1NFCBSS PFCS1NFZASS PFCS1NFZBSS

PFCS1NFZCSS PFCS1NFZHSS PFCS1PJZASS PFCS1PJZBSS

PFCS1PJZCSS PFCS1PJZDSS PFCS1PJZHSS PFCU1NJZCDSS
PFCU1NJZHDSS PFE22KSEAFSS PFIC1NFZABV PFIC1NFZAWV
PFIC1NFZBBV PFIC1NFZBWV PFIC1NFZCBV PFIC1NFZCWV PFIC1NFZDBV
PFIC1NFZDWV PFIE1NFZAAKB PFIE1NFZBAKB PFIE1NFZCAKB
PFQS5PJZASS PFQS5PJZCSS PFQS5PJZHSS PFS23KSHAFSS
PFSA5NJZADSS PFSA5NJZCDSS PFSA5NJZHDSS PFSA5NJZIDSS
PFSE5NJZADSS PFSE5NJZBDSS PFSE5NJZCDSS PFSE5NJZHDSS
PFSF0MFZEBB PFSF0MFZEWW PFSF0MFZFBB PFSF0MFZFWW
PFSF0MFZGBB PFSF0MFZGWW PFSF2MIYGBB PFSF2MIYGWW
PFSF2MIYHBB PFSF2MIYHWW PFSF2MJYHBB PFSF2MJYHWW
PFSF5NFCABB PFSF5NFCACC PFSF5NFCAWW PFSF5NFZABB
PFSF5NFZACC PFSF5NFZAWW PFSF5NFZBBB PFSF5NFZBCC
PFSF5NFZBWW PFSF5NFZCBB PFSF5NFZCCC PFSF5NFZCWW
PFSF5PJZABB PFSF5PJZAWW PFSS0MFZEZSS PFSS0MFZGSS
PFSS0MFZHSS PFSS2MIYGSS PFSS2MIYHSS PFSS2MIYISS
PFSS2MIYJSS PFSS2MJYDSS PFSS2MJYGSS PFSS2MJYHSS
PFSS2MJYISS PFSS2MJYJSS PFSS5NFCASS PFSS5NFZASS
PFSS5NFZBSS PFSS5NFZCSS PFSS5NFZHSS PFSS5PJZASS
PFSS5PJZCSS PGCS1NFZASS PGCS1NFZBSS PGCS1NFZCSS
PGCS1NFZHSS PGCS1PJZASS PGCS1PJZBSS PGCS1PJZCSS
PGCS1PJZHSS PGSS5NFZASS PGSS5NFZBSS PGSS5NFZCSS
PGSS5NFZHSS PGSS5PJZASS PGSS5PJZCSS PHE25TGXBFB
PNS20KSEAFSS PNS20KSHAFSS ZFGB21HZASS ZFGB21HZBSS
ZFGB21HZCSS ZFGB21HZJSS ZFGP21HZASS ZFGP21HZBSS
ZFGP21HZCSS ZFGP21HZJSS